



**QUALIDADE - QUALITY**



**FORMADORA DE CACETES**  
**ROLL DOUGH MOULDER**

# FORMADORA DE CACETES

## ROLL DOUGH MOULDER

ESPECIFICAÇÕES / MODELO SPECIFICATIONS / MODEL	FR3C/600 (3 cilindros)
Alimentação Eléctrica * Electrical Supply *	3/400 V
Motor Motor	0,75 Kw
Consumo Motor Current	2,4 A
Comprimento dos cilindros Cilicer length	605 mm
Diâmetro do cilindro superior Upper cylinder diameter	42 mm
Diâmetro do cilindro inferior Botom Cylinder diameter	105 mm
Capacidade de enformação Moulding capacity	20 – 2500 gr.
Produção/ hora Production per hour	Até/till 5000 pieces
Dimensões Dimensions	(a x b x c x d) 1020 x 1240 x 1220 x 1060 mm
Peso Líquido Net Weight	290Kg
*) Por encomenda a máquina pode ser fornecida com outras tensões (mono ou trifásicas) diferentes das indicadas	
*) Different Electrical supply from the a.m. — To order	

FR3C/600

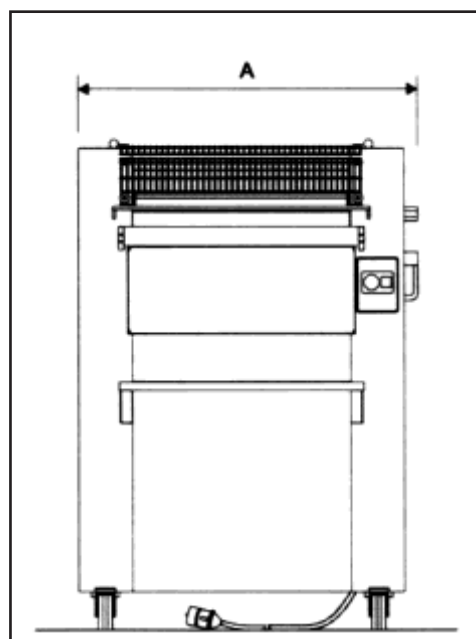

FRENTE

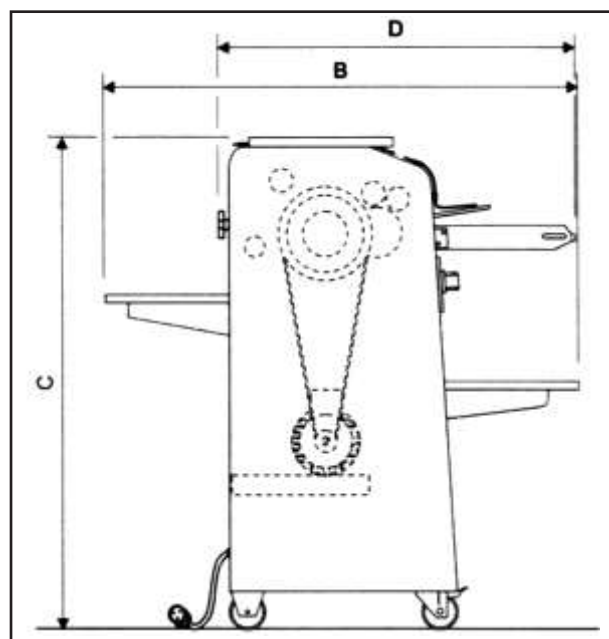

LATERAL

FABRICADO POR:  
MANUFACTURED BY:



Máquinas e Equipamentos para Indústria Alimentar, Lda.  
Rua Lugar do Mouro, n.º 28/40 - Pavilhão 7 - Laurel Park  
2710-453 SINTRA  
Telef.: +351 21 961 33 51 Chamada para a rede fixa Nacional  
Tlm.: +351 968 984 547 Chamada para a rede móvel Nacional  
e-mail: [fabrica@maquindal.pt](mailto:fabrica@maquindal.pt)  
<http://www.maquindal.pt>



REPRESENTANTE:  
DEALER:

